

SCD16H AND SCD110H

● **FEATURES**

- * Halogen-free type
- * Compliance to RoHS product
- * Lead less chip form, no lead damage
- * Low power loss, High efficiency
- * High current capability, low VF
- * Plastic package has Underwriters Laboratory Flammability Classification 94V-0

● **APPLICATION**

- * Switching mode power supply applications
- * Portable equipment battery applications
- * High frequency rectification
- * DC / DC Converter
- * Telecommunication

● **MECHANICAL DATA**

Case : Packed with FRP substrate and epoxy underfilled
Terminals : Pure Tin plated (Lead-Free), solderable per MIL-STD-750, Method 2026.
Polarity : Laser Cathode band marking
Weight : 0.02 gram

● **PACKING**

- * 3,000 pieces per 7" (178mm ± 2mm) reel
- * 4 reels per box
- * 6 boxes per carton

● **OUTLINE DIMENSIONS**

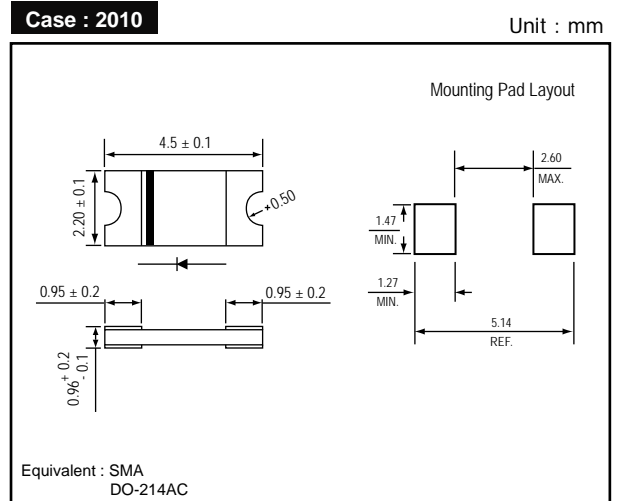

● **MARKING**

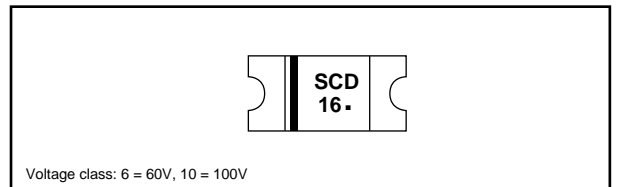

Absolute Maximum Ratings (Ta = 25 °C)

ITEM	Symbol	Conditions	Rating		Unit
			SCD16H	SCD110H	
Repetitive peak reverse voltage	VRRM		60	100	V
Average forward current	IF(AV)		1.0		A
Peak forward surge current	IFSM	8.3ms single half sine-wave	30		A
Operating junction temperature Range	Tj		-55 to +150		°C
Storage temperature Range	TSTG		-55 to +150		°C

Electrical characteristics (Ta = 25 °C)

ITEM	Symbol	Conditions	Type	Min.	Typ.	Max.	Unit	
Forward voltage (NOTE 1)	VF	IF = 0.1A	SCD16H	-	0.38	-	V	
		IF = 0.5A		-	0.48	-		
		IF = 1.0A		-	0.60	0.70		
			IF = 0.1A	SCD110H	-	0.45	-	V
			IF = 0.5A		-	0.63	-	
			IF = 1.0A		-	0.76	0.85	
Repetitive peak reverse current	IRRM	VR = Max. VRRM , Ta = 25 °C		-	0.02	0.20	mA	
Junction capacitance	Cj	VR = 4V, f = 1.0 MHz		-	110	-	pF	
Thermal resistance	Rth(JA)	Junction to ambient (NOTE 2)		-	88	-	°C/W	
	Rth(JL)	Junction to lead (NOTE 2)		-	28	-	°C/W	

NOTES : (1) Pulse test width PW=300usec , 1% duty cycle.
 (2) Mounted on P.C. board with 0.2 x 0.2"(5.0 x5.0mm) copper pad areas.

FIG.1 - FORWARD CURRENT DERATING CURVE

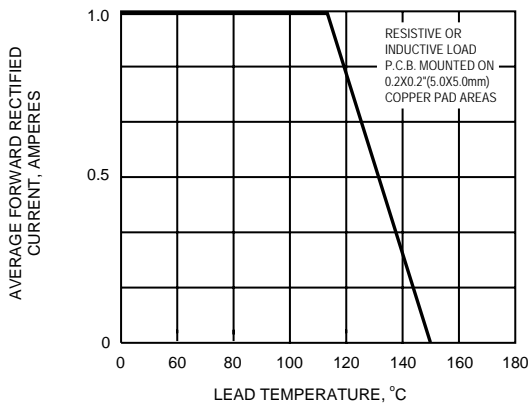

FIG.2 - MAXIMUM NON-REPETITIVE PEAK FORWARD SURGE CURRENT

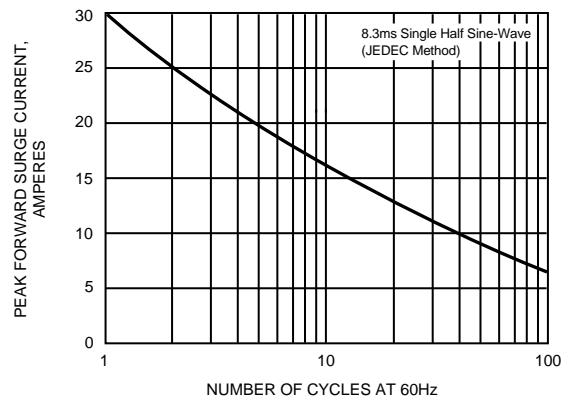

FIG.3 - TYPICAL INSTANTANEOUS FORWARD CHARACTERISTICS

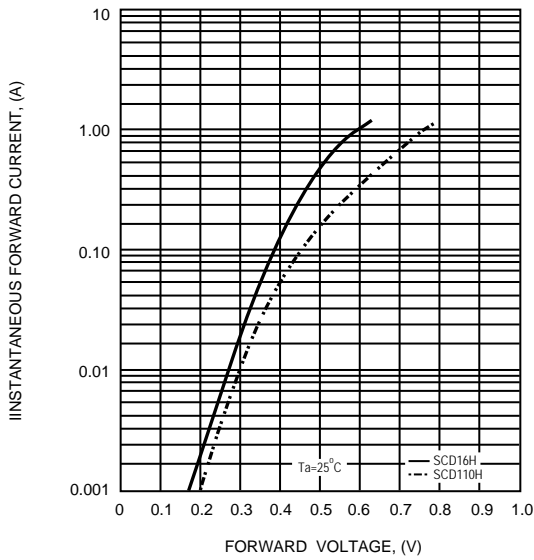

FIG.4 - TYPICAL REVERSE CHARACTERISTICS

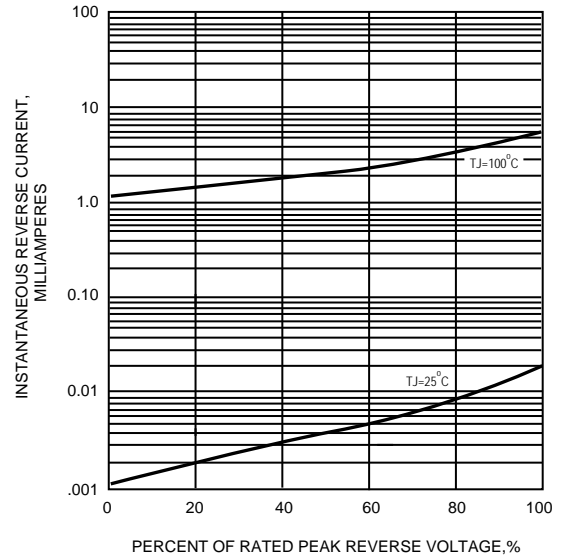

FIG.5 - TYPICAL JUNCTION CAPACITANCE

